

Wii™



Disney
HIGH SCHOOL MUSICAL

Sing It!



INSTRUCTION BOOKLET



The Official Seal is your assurance that this product is licensed or manufactured by Nintendo. Always look for this seal when buying video game systems, accessories, games and related products.



Manufactured under license from Dolby Laboratories. Dolby, Pro Logic, and the double-D symbol are trademarks of Dolby Laboratories.

This game is presented in Dolby Pro Logic II. To play games that carry the Dolby Pro Logic II logo in surround sound, you will need a Dolby Pro Logic II, Dolby Pro Logic or Dolby Pro Logic IIx receiver. These receivers are sold separately.



Nintendo, Wii and the Official Seal are trademarks of Nintendo. © 2006 Nintendo.

Licensed by Nintendo



Disney HIGH SCHOOL MUSICAL

Controls	2
Menu Controls	3
Special Sound Effects	3
Using the Microphone	4
Join the East High Drama Club	5
Main Menu	6
Sing Along with <i>HSM Sing It!</i>	7
Voice Lessons	8
Scoring	9
Quick Play	10
Story Mode	10
Party Mode	11
Profile	13
Extras	15
Limited Warranty	21
Customer Support	21



Controls

Connect the **Nunchuk** to the **Wii Remote's** External Extension Connection. See the **Wii Console's** instruction manual for details.

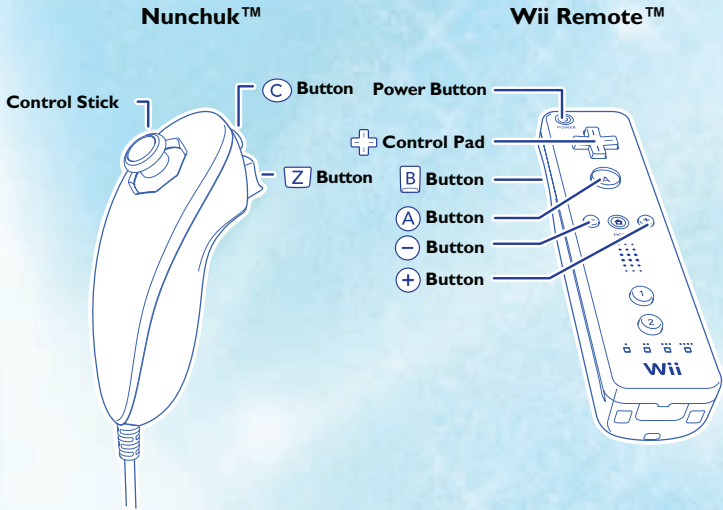

Nunchuk Neutral Position Reset

NOTE: If the **Control Stick** is moved out of neutral position when the power is turned on, or when connecting to the **Wii Remote**, that position will be set as neutral position, causing incorrect game control during gameplay. To reset the **Control Stick**, allow it to return to the normal neutral position, then simultaneously hold down the **A B + - Buttons** on the **Wii Remote** for three seconds.

⚠ CAUTION: WRIST STRAP USE

Please use the wrist strap to help prevent injury to other people or damage to surrounding objects or the **Wii Remote** in case you accidentally let go of the **Wii Remote** during game play.

Also remember the following:

- Make sure all players put on the wrist strap properly when it is their turn.
- Do not let go of the **Wii Remote** during game play.
- Dry your hands if they become moist.
- Allow adequate room around you during game play and make sure that all areas you might move into are clear of other people and objects.
- Stay at least three feet from the television

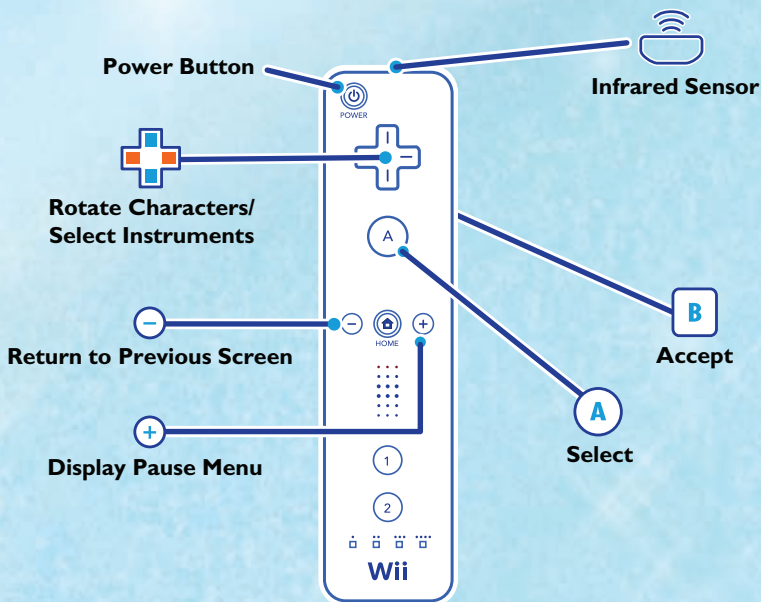

MENU CONTROLS

Breaking into song couldn't be easier! Just point your **Wii Remote** at the screen, highlight a menu option and press the **A Button** to select it.

Wii Remote

- A Button** Select
- B Button** Accept
- − Button** Return to previous screen

SPECIAL SOUND EFFECTS

Nunchuk Trigger special sound effects (optional)

Wii Remote

- + Control Pad** Select instrument set
Trigger special sound effects (up to 4 Remotes)

USING THE MICROPHONE

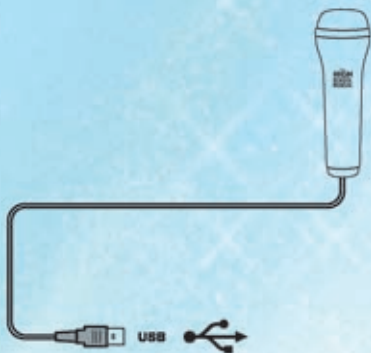

MICROPHONE CONNECTION

Connecting your microphone to the Wii Console is a snap.

1. Make sure the power is switched OFF.
2. Attach your microphone's USB connector to one of the USB connections on the back of your **Wii**.
3. Turn the power ON.
4. Load *Disney High School Musical: Sing It!*
5. Sing!

Your microphone must be plugged in at all times while playing the game. Visit Options (look in Extras) to adjust your microphone's sensitivity.

Let's have fun
ALL for ONE

Join the East High Drama Club!

Troy and Gabriella *may* have been afraid to sing in front of their friends and family. And their friends at East High School *may* have wanted the budding singers to give up their musical dreams and to *stick to the status quo*. But with ***Disney High School Musical: Sing It!*** there's nothing to stop you from taking the stage and truly *breaking free*. It's your best chance to join the East High Drama Club and show everybody what you've got.

A group of five young people from the Disney High School Musical: Sing It! cast are standing together against a light blue background. From left to right: a young woman with dark hair wearing a denim jacket over a striped top; a young man with curly brown hair wearing a red, white, and blue jacket; a young man with brown hair wearing a red sweater; a young woman with long dark hair wearing a colorful floral dress; and a young man wearing a teal hat, a teal shirt, and a white jacket. They are all smiling and looking towards the camera.

Even better, ***Disney High School Musical: Sing It!*** features a unique duet karaoke system so you and a friend can both join the drama club. Together you can sing your way through the story of the original *High School Musical* movie as soloists or as a talented duet. With over twenty songs from both *High School Musical* movies plus bonus songs – you'll have plenty of hits to host a karaoke party for seven of your friends.

So, take a moment to review these instructions then get out there and show them what you've got!

Main Menu



QUICK PLAY

Play any of the songs that you have already unlocked. No muss, no fuss. Just pick a profile, a song and a stage and get up there and sing!

STORY MODE

It's the *start of something new*. Sing along with Gabriella, Troy, Sharpay, Ryan and the rest of the East High Drama Club as you *ride that rhythm* all the way through the story of the Disney Channel Original Movie, *High School Musical*.

PARTY MODE

Invite up to seven of your friends over and find out who has the best voice – or just get together to create wonderful music in duets and solo performances.

EXTRAS

So maybe there aren't any songs here, but in Extras you can set game Options such as Auto Save or Sound, check your Progress through the game's unlockables, see the Credits to find out who made the game, and much more! View bonus footage of the *Disney High School Musical* cast by clicking any of the exclusive content options.

Sing Along with HSM Sing It!



TROY



It's all about song for members of East High's drama club. Here's how you can keep up with the band.

LYRICS

Song lyrics will appear on the screen – sing in time for the best score.

OVERALL SCORE

The singer's total score for the song.

CURRENT MULTIPLIER

Sing phrases flawlessly and earn score multipliers!

CURRENT PHRASE SCORE

The singer's score for the current phrase.

DESIRED PITCH

Where the singer's voice *should* be. The higher the bar, the higher the desired pitch.

CURRENT PITCH

Where the singer's voice *actually* is. The closer it is to the desired pitch, the higher the singer's score.

PERFORMANCE METER

More stars mean better singing. How many stars can you light up? **7**

VOICE LESSONS

It's time to switch off those cell phones and *get'cha head in the game!* With a little practice you'll feel like you can *bop to the top* in no time!

MICROPHONE USE

Position the microphone an inch or so from your mouth and try to keep it there throughout your performance. You can adjust the microphone's sensitivity in the Options Menu.

PITCH

Keep an eye on the pitch meter when you are on stage. The basketball shows you the actual pitch of your voice as you're singing, going up and down the pitch indicator. If it goes down, you should try to sing higher; if it goes too high, you need to lower your pitch. Try to keep the basketball on the actual pitch lines to sing the words accurately!

CADENCE

Don't rush through the lyrics – and don't take too long singing them, either. Try to voice the words just as they cross under the pitch meter.

PHRASES

Songs are divided into phrases (or pieces of song) that are several words long. If you sing a phrase well, without any mistakes in pitch or cadence, you will earn score multipliers. Try to put together consecutive winning phrases to earn multiple multipliers.

LONG NOTES

Some notes need to be held longer than others. For these, try to voice the note with a vowel sound rather than a consonant sound. The microphone is much better at picking up vowel sounds. However, you can't hold a long note for very long if you don't have enough breath to sing it. So, in addition to practicing how to sing in pitch and how to sing in rhythm, you will also need to practice how and when to breathe. Whew!

PRACTICE

Practice makes perfect. Work hard and your delivery will be that much smoother!

And remember: you can always visit Quick Play for more practice with songs you've unlocked.

SCORING

Scoring couldn't be simpler. Sing in pitch with the music and sing in time with the lyrics to earn maximum points. Phrases sung in time and in pretty good pitch earn score multipliers. Phrases sung in perfect and almost-perfect pitch earn the highest multipliers.

In addition to the overall score, the final score screen shows you the letter grade given for your performance.

Disney HIGH SCHOOL MUSICAL

Song Complete

Song: **Bop to the Top**

Gabriella **900045**

5 Rock Star

High Scores

Gabriella **900045**

All Time **900000**

Accept **A**



MUSIC

QUICK PLAY

Perfect for a quick song (or three), Quick Play offers all the excitement of life on the East High stage in a smaller, quicker package!



To get started, select a player profile (see Profile, under Extras, to learn more about creating a profile), choose a song, a stage, and a duet partner and then hit “Go!” to hit the stage. You can also play alone if you want to!

To preview a song, highlight it on the list, and then press the **A Button**. You can also preview stages the same way.

STORY MODE

Sing alone or sing with a friend as you follow the story of *Disney High School Musical* – from Troy and Gabriella’s first new year’s eve duet to the entire cast’s awesome finale on the East High School stage. If you perform the songs well, you’ll unlock more songs to sing, more environments to sing in, more characters to sing along with and more outfits in which to dress them.

The game will choose a song and a stage for you, depending on where you are in the story.

PARTY MODE

Challenge your friends to a “sing off” in Party Mode or just get together and sing your favorite songs from *Disney High School Musical* movies and stage productions. You can sing alone or as part of a duet. Up to eight players can join Party Mode.



New players can join the game between rounds, and others can leave without ending the game for everybody else. And if anybody needs a break, singers can skip a turn if they like, too.

I don't
Dance!

CHARACTER SELECTION

Each player can select a favorite East High Drama Club singer to perform with and then dress them in their favorite outfits and accessories. If you sing well enough, you will unlock more characters and more outfits.



Players joining the game late will also get a chance to choose a profile and character.

DUETS

When you sing with a friend, his or her score and indicators such as pitch bars and lyrics are kept on the top half of the screen. Duets are available in Party Mode, Quick Play Mode, and in Story Mode, too.

Duets work best with two microphones, but singers can also share a single microphone and pass it back and forth as each singer performs his or her part of the song.

AUDIENCE

Singers waiting for their next turn at the microphone can create sound effects on the stage with their **Wii Remotes**. Try new moves with your **Wii Remote** – twist it, shake it, roll it, wave it – *anything can happen when you take a chance.*

Use the **+** **Control Pad** to select a musical instrument for your sound effects.

Your **Nunchuk** will also trigger effects. Try it and see what happens!

PROFILE

Choose one of your favorite *High School Musical* characters and then customize him or her to create your own personal profile. Your profile stores your progress through the game and your top scores, too. After you come up with a great name, use the **Wii Remote** to cycle through outfits and accessories and select with the **A Button**. Now you're ready to hit the stage!



As you sing more songs, you will unlock more outfits and accessories for your profile character to wear.

The Future is a Big Place

TAKE FIVE

If your voice needs a break, press the **+** Button to open the Pause Menu. Select RESUME to return to the show, or choose QUIT to exit to the Main Menu. Select Sound Settings to adjust sound and microphone settings.

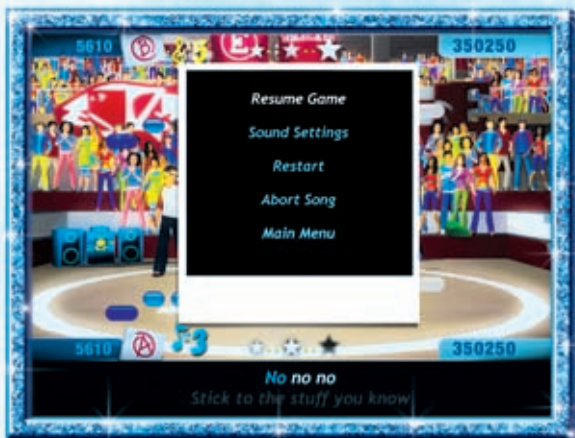

Extras

OPTIONS



FILE SETTINGS

Disney High School Musical: Sing It! will save your progress automatically, but you can turn this feature off if you like. If you do switch Auto Save to OFF, remember to return to this menu to save your progress manually.

SOUND SETTINGS

Highlight an option with your **Wii Remote** and choose it by pressing the **A Button**. Then use the sliders to adjust Player Volume (That's you!), Character Volume, Microphone Sensitivity, Music Volume, and Crowd/Sound Effects volume.

High School
MUSICAL

UNLOCKED GOODIES

If you're curious about how many more songs and stages and characters and outfits you can still unlock, this is where to look! And if you need some advice about how to unlock something you haven't been able to unlock, this is where to look, too!



BET
on it